



OX
WORLDWIDE



TBC // ST // TMC
TROLLEYS
CATALOGUE



OUR COMPANY

A BRIEF INTRODUCTION

We created our company in 1992 and since then, we have been specializing in lifting and maintenance of loads, working for the industrial and naval sectors.

OX WORLDWIDE is a division born from this previous experience that manufactures and commercializes very specific products of maintenance. We introduce our OX TROLLEYS (self-propelled trolleys), our OX CUSHIONS (air cushions system), and OX-ATTACK (dragging systems).

OUR COMPANY.

The products and the advising we supply are our standards of quality. We are provided of a qualified staff, proper facilities and we can send you any kind of information about the products you demand: sketches, detail layouts, certificates, instruction manuals, etc. Without compromise, consult us and we will advise you.

CERTIFICATE OF APPROVAL ISO 9001.

Our department of quality is guaranteed by periodic inspections and approval certificates by Lloyd Register Quality Assurance.



Emilio Blasco
Management.



Jordi Ortiz
Technical Office.



Miguel Ruiz
Sales Director.



Ruben Blasco
Export Area 1.
(Europe, Africa and Asia).



Carlos Viegas
Export Area 2.
(Central Europe).



David García
Export Area 3.
(Spain).



Eduard Sans
Export Area 4.
(USA, Canada and Oceania).



Daniel Navarro
Export Area 5.
(South America).



Manel Amat
Manufacture.



M^o Angels Batlle
Accounting.



Carme Canalda
Administration.



INDEX

OX-ST // OX-TMC

OX-ST-030 + OX-CTS-030	p.5
OX-TMC-030 + OX-CT-030	p.6
OX-ST-060 + OX-CTS-060	p.7
OX-TMC-060 + OX-CT-060	p.8
OX-ST-100 + OX-CTS-100	p.9
OX-TMC-100 + OX-CT-100	p.10
OX-ST-150 + OX-CTS-150	p.11
OX-TMC-150 + OX-CT-150	p.12
OX-ST-200 + OX-CTS-200	p.13
OX-TMC-200 + OX-CT-200	p.14

OX-TBC

OX-TBC-030 + OX-CT-030	p.16
OX-TBC-060 + OX-CT-060	p.17
OX-TBC-100 + OX-CT-100	p.18
OX-TBC-150 + OX-CT-150	p.19

SEVERAL APPLICATIONS	p.20
-----------------------------------	------



ST // TMC
TROLLEYS



OX-ST-030 FEATURES

- Self propelled trolleys (turn 360°).
- Power: 380 Vac III 50 Hz. Optional: different tensions and frequencies.
- Capacity: 30 tons.
- Motorized trolley capacity: 15 tons.
- Rear trolleys capacity: 15 tons.
- Power chain in every wheel.
- 8 polyamide wheels of 160 x 90 mm.
- Motorized trolley weight: 400 kg.
- Supplied with a remote control and an auxiliary corded handset.
- Rotating load main platform.
- Speed: from 3 to 5 mts/min.
- Trolley warranty: 12 months.
- Wheels warranty: 6 months.

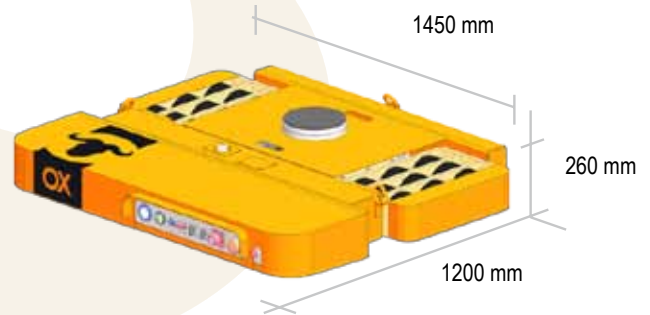

OX-ST-030

OX-CTS-030 FEATURES

- Pair of rear trolleys + bars.
- Pair of trolleys capacity: 15 tons.
- 4 wheels per trolley of 160 x 90 mm.
- Weight: 40 kg per trolley.

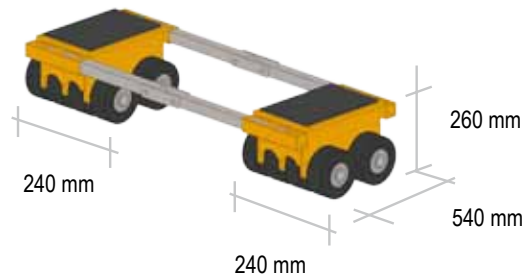

OX-CTS-030

OPTIONAL

OX-MBS-030 FEATURES

- Optional accessory for the OX-ST-030 trolley.
- Consists of a traction battery pack.
- Battery life = 1 hour of continuous work at full charge.
- Charge time = 6 hours
- Battery warranty = 6 months



OX-MBS-030

OX-TMC-030 FEATURES

- Self propelled trolleys (turn 360°).
- Power: 380 Vac III 50 Hz. Optional: different tensions and frequencies. Battery module (OX-MB-030).
- Capacity: 30 tons.
- Motorized trolley capacity: 15 tons.
- Rear trolleys capacity: 15 tons.
- Chain and pinion drive in every wheel.
- 8 polyamide wheels of 160 x 90 mm.
- Motorized trolley weight: 350 kg.
- Supplied with a remote control and an auxiliary corded handset.
- Main rotating hydraulic jack (raises the load 10 cms.)
- Speed: from 3 to 5 mts/min.
- Trolley warranty: 12 months.
- Wheels warranty: 6 months.

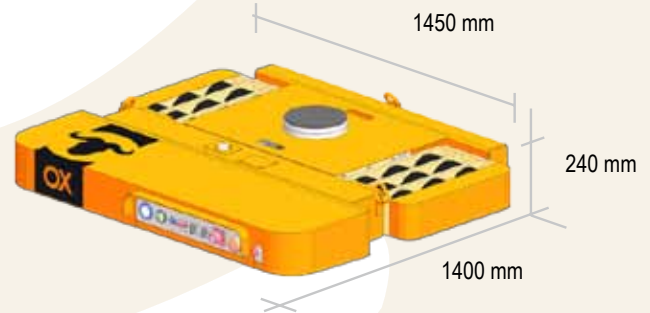

OX-TMC-030

OX-CT-030 FEATURES

- Pair of rear trolleys + bars.
- Pair of trolleys capacity: 15 tons.
- 4 wheels per trolley of 160 x 90 mm.
- Weight: 40 kg per trolley.

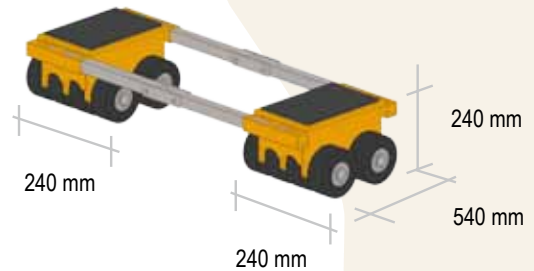

OX-CT-030

OPTIONAL

OX-MBT-030 FEATURES

- Optional accessory for the OX-TMC-030 trolley.
- Consists of a traction battery pack.
- Battery life = 1 hour of continuous work at full charge.
- Charge time = 6 hours
- Battery warranty = 6 months



OX-MBT-030

OX-ST-060 FEATURES

- Self propelled trolleys (turn 360°).
- Power: 380 Vac III 50 Hz. Optional: different tensions and frequencies.
- Capacity: 60 tons.
- Motorized trolley capacity: 30 tons.
- Rear trolleys capacity: 30 tons.
- Power chain in every wheel.
- 12 polyamide wheels of 200 x 100 mm.
- Motorized trolley weight: 750 kg.
- Supplied with a remote control and an auxiliary corded handset.
- Rotating load main platform.
- Speed: from 3 to 5 mts/min.
- Trolley warranty: 12 months.
- Wheels warranty: 6 months.

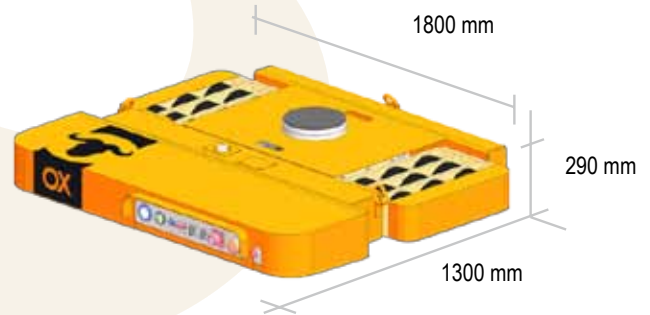

OX-ST-060

OX-CTS-060 FEATURES

- Pair of rear trolleys + bars.
- Pair of trolleys capacity: 30 tons.
- 6 wheels per trolley of 200 x 100 mm.
- Weight: 70 kg per trolley.

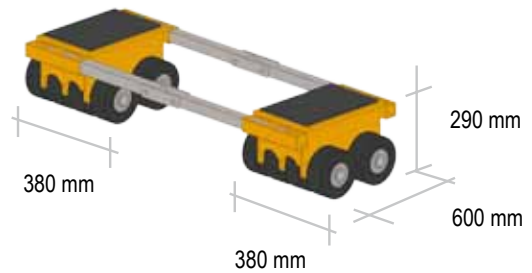

OX-CTS-060

OPTIONAL

OX-MBS-060 FEATURES

- Optional accessory for the OX-ST-030 trolley.
- Consists of a traction battery pack.
- Battery life = 1 hour of continuous work at full charge.
- Charge time = 6 hours
- Battery warranty = 6 months



OX-MBS-060

OX-TMC-060 FEATURES

- Self propelled trolleys (turn 360°).
- Power: 380 Vac III 50 Hz. Optional: different tensions and frequencies. Battery module (OX-MB-060).
- Capacity: 60 tons.
- Motorized trolley capacity: 30 tons.
- Rear trolleys capacity: 30 tons.
- Chain and pinion drive in every wheel.
- 12 polyamide wheels of 200 X 100 mm.
- Motorized trolley weight: 750 kg.
- Supplied with a remote control and an auxiliary corded handset.
- Main rotating hydraulic jack (raises the load 10 cms.)
- Speed: 5 mts/min.
- Trolley warranty: 12 months.
- Wheels warranty: 6 months.

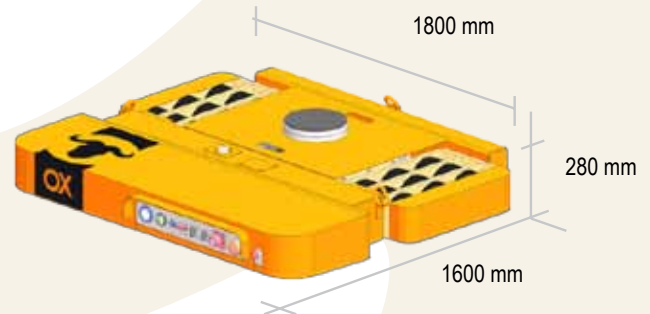

OX-TMC-060

OX-CT-060 FEATURES

- Pair of rear trolleys + bars.
- Pair of trolleys capacity: 30 tons.
- 6 wheels per trolley of 200 x 100 mm.
- Weight: 70 kg per trolley.

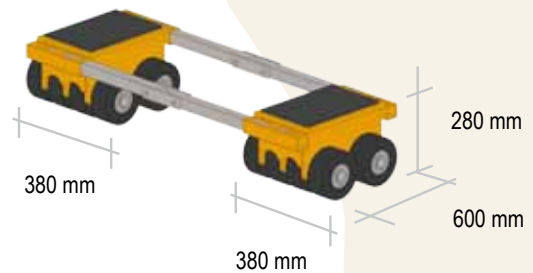

OX-CT-060

OPTIONAL

OX-MBT-060 FEATURES

- Optional accessory for the OX-TMC-060 trolley.
- Consists of a traction battery pack.
- Battery life = 1 hour of continuous work at full charge.
- Charge time = 6 hours
- Battery warranty = 6 months



OX-MBT-060

OX-ST-100 FEATURES

- Self propelled trolleys (turn 360°).
- Power: 380 Vac III 50 Hz. Optional: different tensions and frequencies.
- Capacity: 100 tons.
- Motorized trolley capacity: 50 tons.
- Rear trolleys capacity: 50 tons.
- Power chain in every wheel.
- 18 polyamide wheels of 200 x 100 mm.
- Motorized trolley weight: 1000 kg.
- Supplied with a remote control and an auxiliary corded handset.
- Rotating load main platform.
- Speed: from 3 to 5 mts/min.
- Trolley warranty: 12 months.
- Wheels warranty: 6 months.

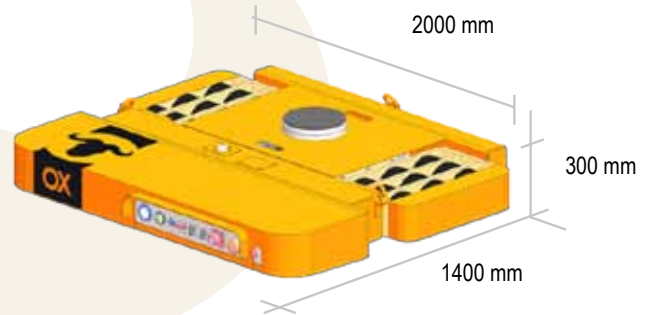

OX-ST-100

OX-CTS-100 FEATURES

- Pair of rear trolleys + bars.
- Pair of trolleys capacity: 30 tons.
- 8 wheels per trolley of 200 x 100 mm.
- Weight: 90 kg per trolley.

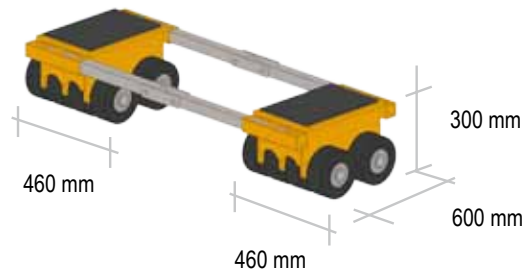

OX-CTS-100

OPTIONAL

OX-MBS-100 FEATURES

- Optional accessory for the OX-ST-100 trolley.
- Consists of a traction battery pack.
- Battery life = 1 hour of continuous work at full charge.
- Charge time = 6 hours
- Battery warranty = 6 months



OX-MBS-100

OX-TMC-100 FEATURES

- Self propelled trolleys (turn 360°).
- Power: 380 Vac III 50 Hz. Optional: different tensions and frequencies. Battery module (OX-MB-100).
- Capacity: 100 tons.
- Motorized trolley capacity: 50 tons.
- Rear trolleys capacity: 50 tons.
- Chain and pinion drive in every wheel.
- 18 polyamide wheels of 200 X 100 mm.
- Motorized trolley weight: 1100 kg.
- Supplied with a remote control and an auxiliary corded handset.
- Main rotating hydraulic jack (raises the load 10 cms.)
- Speed: 5 mts/min.
- Trolley warranty: 12 months.
- Wheels warranty: 6 months.

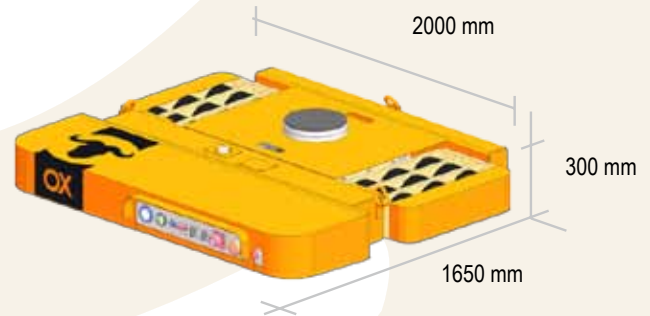

OX-TMC-100

OX-CT-100 FEATURES

- Pair of rear trolleys + bars.
- Pair of trolleys capacity: 50 tons.
- 6 wheels per trolley of 200 x 100 mm.
- Weight: 70 kg per trolley.

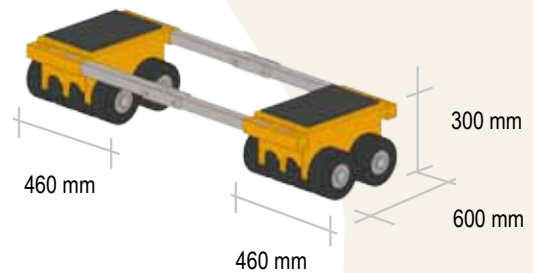

OX-CT-100

OPTIONAL

OX-MBT-100 FEATURES

- Optional accessory for the OX-TMC-100 trolley.
- Consists of a traction battery pack.
- Battery life = 1 hour of continuous work at full charge.
- Charge time = 6 hours
- Battery warranty = 6 months



OX-MBT-100

OX-ST-150 FEATURES

- Self propelled trolleys (turn 360°).
- Power: 380 Vac III 50 Hz. Optional: different tensions and frequencies.
- Capacity: 150 tons.
- Motorized trolley capacity: 75 tons.
- Rear trolleys capacity: 75 tons.
- Power chain in every wheel.
- 18 polyamide wheels of 250 x 140 mm.
- Motorized trolley weight: 1750 kg.
- Supplied with a remote control and an auxiliary corded handset.
- Rotating load main platform.
- Speed: from 3 to 5 mts/min.
- Trolley warranty: 12 months.
- Wheels warranty: 6 months.

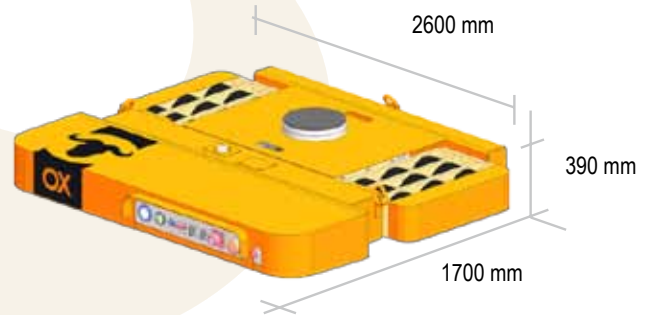

OX-ST-150

OX-CTS-150 FEATURES

- Pair of rear trolleys + bars.
- Pair of trolleys capacity: 30 tons.
- 8 wheels per trolley of 250 x 140 mm.
- Weight: 200 kg per trolley.

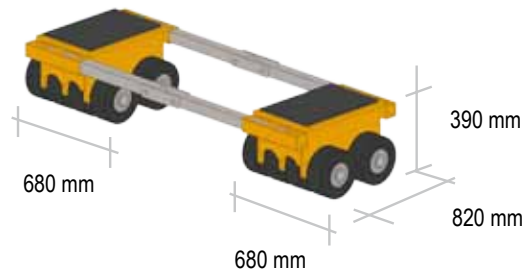

OX-CTS-150

OPTIONAL

OX-MBS-150 FEATURES

- Optional accessory for the OX-ST-150 trolley.
- Consists of a traction battery pack.
- Battery life = 1 hour of continuous work at full charge.
- Charge time = 6 hours
- Battery warranty = 6 months



OX-MBS-150

OX-TMC-150 FEATURES

- Self propelled trolleys (turn 360°).
- Power: 380 Vac III 50 Hz. Optional: different tensions and frequencies. Battery module (OX-MB-150).
- Capacity: 150 tons.
- Motorized trolley capacity: 75 tons.
- Rear trolleys capacity: 75 tons.
- Chain and pinion drive in every wheel.
- 18 polyamide wheels of 250 x 140 mm.
- Motorized trolley weight: 1700 kg.
- Supplied with a remote control and an auxiliary corded handset.
- Main rotating hydraulic jack (raises the load 10 cms.)
- Speed: 5 mts/min.
- Trolley warranty: 12 months.
- Wheels warranty: 6 months.

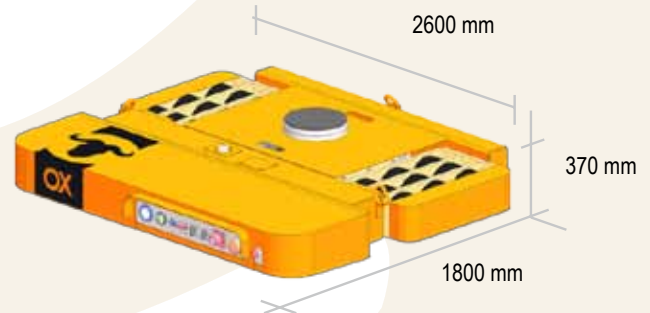

OX-TMC-150

OX-CT-150 FEATURES

- Pair of rear trolleys + bars.
- Pair of trolleys capacity: 75 tons.
- 6 wheels per trolley of 250 x 140 mm.
- Weight: 200 kg per trolley.

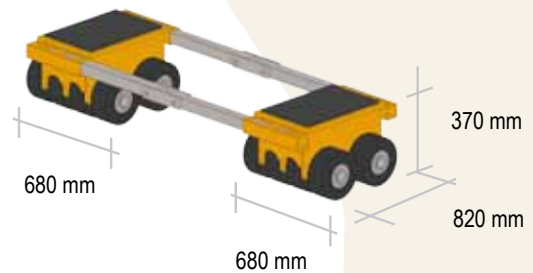

OX-CT-150

OPTIONAL

OX-MBT-150 FEATURES

- Optional accessory for the OX-TMC-150 trolley.
- Consists of a traction battery pack.
- Battery life = 1 hour of continuous work at full charge.
- Charge time = 6 hours
- Battery warranty = 6 months



OX-MBT-150

OX-ST-200 FEATURES

- Self propelled trolleys (turn 360°).
- Power: 380 Vac III 50 Hz. Optional: different tensions and frequencies.
- Capacity: 200 tons.
- Motorized trolley capacity: 100 tons.
- Rear trolleys capacity: 100 tons.
- Power chain in every wheel.
- 18 polyamide wheels of 300 x 155 mm.
- Motorized trolley weight: 2600 kg.
- Supplied with a remote control and an auxiliary corded handset.
- Rotating load main platform.
- Speed: from 3 to 5 mts/min.
- Trolley warranty: 12 months.
- Wheels warranty: 6 months.

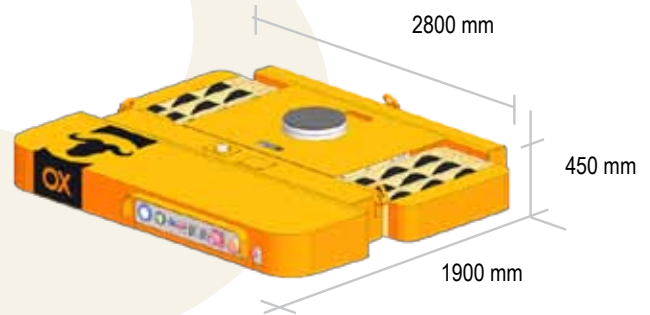

OX-ST-200

OX-CTS-200 FEATURES

- Pair of rear trolleys + bars.
- Pair of trolleys capacity: 100 tons.
- 8 wheels per trolley of 300 x 155 mm.
- Weight: 240 kg per trolley.

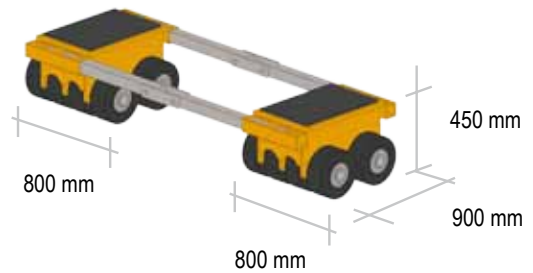

OX-CTS-200

OPTIONAL

OX-MBS-200 FEATURES

- Optional accessory for the OX-ST-200 trolley.
- Consists of a traction battery pack.
- Battery life = 1 hour of continuous work at full charge.
- Charge time = 6 hours
- Battery warranty = 6 months



OX-MBS-200

OX-TMC-200 FEATURES

- Self propelled trolleys (turn 360°).
- Power: 380 Vac III 50 Hz. Optional: different tensions and frequencies. Battery module (OX-MB-200).
- Capacity: 200 tons.
- Motorized trolley capacity: 100 tons.
- Rear trolleys capacity: 100 tons.
- Chain and pinion drive in every wheel.
- 18 polyamide wheels of 300 x 155 mm.
- Motorized trolley weight: 2500 kg.
- Supplied with a remote control and an auxiliary corded handset.
- Main rotating hydraulic jack (raises the load 10 cms.)
- Speed: 5 mts/min.
- Trolley warranty: 12 months.
- Wheels warranty: 6 months.

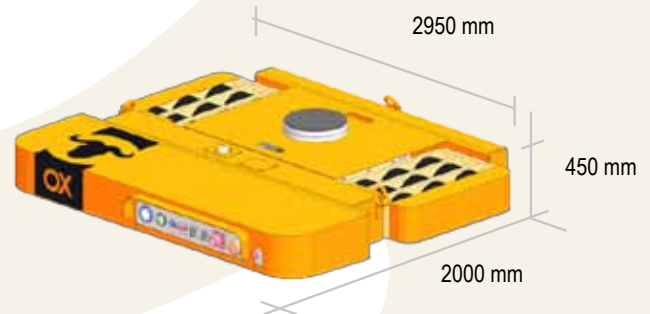

OX-TMC-200

OX-CT-200 FEATURES

- Pair of rear trolleys + bars.
- Pair of trolleys capacity: 100 tons.
- 6 wheels per trolley of 300 x 155 mm.
- Weight: 240 kg per trolley.

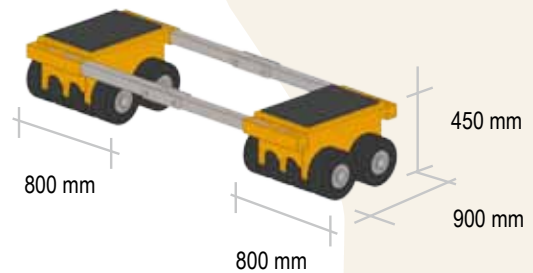

OX-CT-200

OPTIONAL

OX-MBT-200 FEATURES

- Optional accessory for the OX-TMC-200 trolley.
- Consists of a traction battery pack.
- Battery life = 1 hour of continuous work at full charge.
- Charge time = 6 hours
- Battery warranty = 6 months



OX-MBT-200



TBC
TROLLEYS



OX-TBC 030 FEATURES

- Self propelled trolleys (turn 360°).
- Power: 380 Vac III 50 Hz and by battery module.
- Optional: different tension and frequency.
- Total capacity: 30 tons.
- Trolley capacity: 15 tons.
- Rear-trolley capacity: 15 tons.
- Chain and pinion drive in every wheel.
- 8 polyamide wheels of 160 x 90 mm.
- Motorized trolley weight: 430 kg.
- Supplied with a remote control and an auxiliar corded handset.
- Main rotating hydraulic jack (raises 7 cms. the whole load)
- Speed: 5 mts/min.
- Trolley warranty: 12 months.
- Wheels warranty: 6 months.

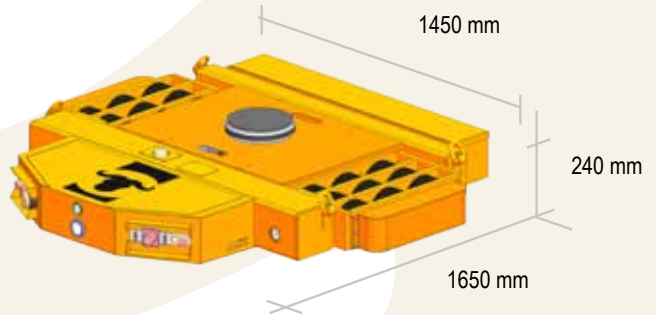

OX-TBC 030

OX-CT 030 FEATURES

- Pair of rear trolleys + bars.
- Pair of trolleys capacity: 15 tons.
- 4 wheels per trolley of 160 x 90 mm.
- Weight: 76 kg per pair.

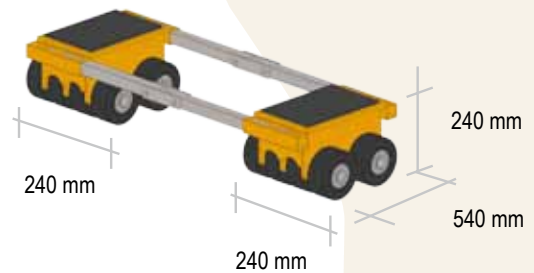

OX-CT 030



OX-TBC 060 FEATURES

- Self propelled trolleys (turn 360°).
- Power: 380 Vac III 50 Hz and by battery module.
- Optional: different tension and frequency.
- Total capacity: 60 tons.
- Capacity: 30 tons.
- Rear-trolley capacity: 30 tons.
- Chain and pinion drive in every wheel.
- 12 polyamide wheels of 200 x 100 mm.
- Motorized trolley weight: 900 kg.
- Supplied with a remote control and an auxiliary corded handset.
- Main rotating hydraulic jack (raises 7 cms. the whole load)
- Speed: 5 mts/min.
- Trolley warranty: 12 months.
- Wheels warranty: 6 months.

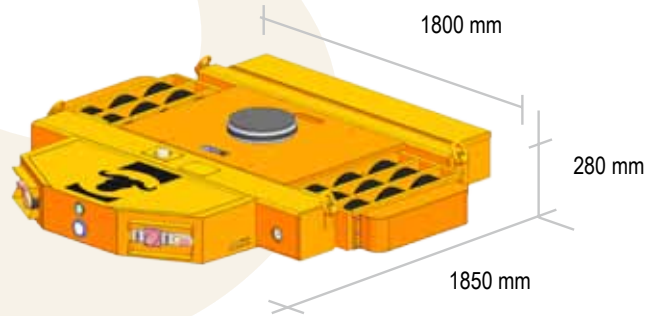

OX-TBC 060

OX-CT 060 FEATURES

- Pair of rear trolleys + bars.
- Pair of trolleys capacity: 30 tons.
- 4 wheels per trolley of 200 x 100 mm.
- Weight: 130 kg per pair.

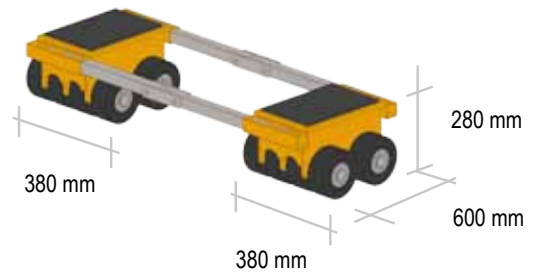

OX-CT 060



OX-TBC 100 FEATURES

- Self propelled trolleys (turn 360°).
- Power: 380 Vac III 50 Hz and by battery module.
- Optional: different tension and frequency.
- Total capacity: 100 tons.
- Trolley capacity: 50 tons.
- Rear-trolley capacity: 50 tons.
- Chain and pinion drive in every wheel.
- 8 polyamide wheels of 200 x 100mm.
- Motorized trolley weight: 1350 kg.
- Supplied with a remote control and an auxiliar corded handset.
- Main rotating hydraulic jack (raises 7 cms. the whole load)
- Speed: 5 mts/min.
- Trolley warranty: 12 months.
- Wheels warranty: 6 months.

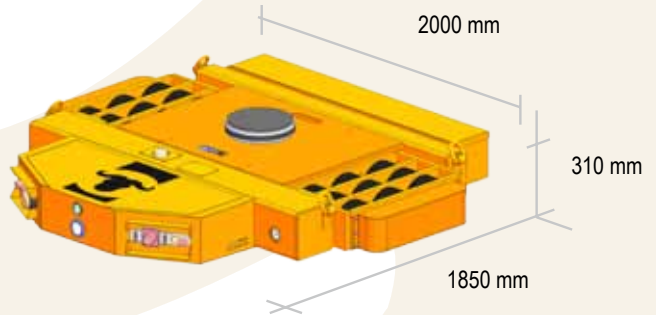

OX-TBC 100

OX-CT 100 FEATURES

- Pair of rear trolleys + bars.
- Pair of trolleys capacity: 50 tons.
- 4 wheels per trolley of 200 x 100 mm.
- Weight: 170 kg per pair.

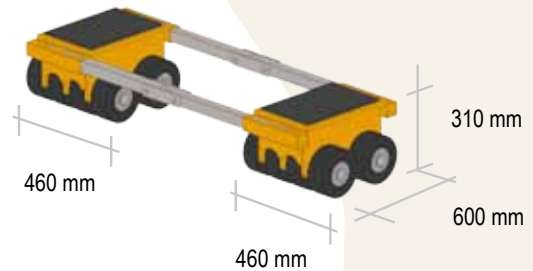

OX-CT 100



OX-TBC 150 FEATURES

- Self propelled trolleys (turn 360°).
- Power: 380 Vac III 50 Hz and by battery module.
- Optional: different tension and frequency.
- Total capacity: 150 tons.
- Capacity: 75 tons.
- Rear-trolley capacity: 75 tons.
- Chain and pinion drive in every wheel.
- 18 polyamide wheels of 250 x 140 mm.
- Motorized trolley weight: 2000 kg.
- Supplied with a remote control and an auxiliary corded handset.
- Main rotating hydraulic jack (raises 7 cms. the whole load)
- Speed: 5 mts/min.
- Trolley warranty: 12 months.
- Wheels warranty: 6 months.

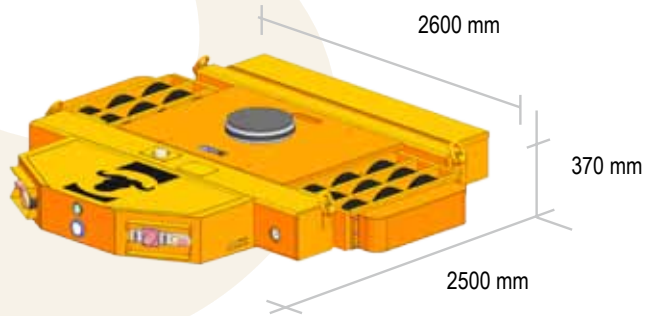

OX-TBC 150

OX-CT 150 FEATURES

- Pair of rear trolleys + bars.
- Pair of trolleys capacity: 75 tons.
- 8 wheels per trolley of 250 x 140 mm.
- Weight: 210 kg per pair.

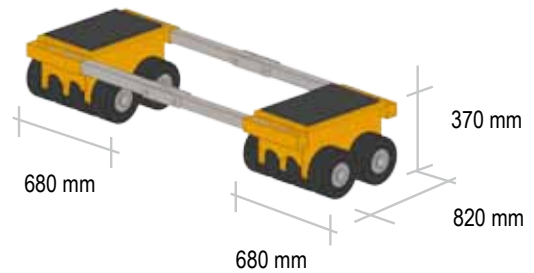

OX-CT 150



OX-ST 150: PRESS PLACING.

Placing of a press inside a warehouse with the help of a hydraulic lifter. ST Trolley is placed under it. Total load weight: 80 tons.



OX-TMC 100: LOAD TESTING.

Load testing with counterweights on the outside of a self-propelled cranes company.
The load total weight was of 100 tons.



OX
WORLDWIDE

